

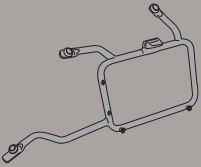

PLR5108 – KLR5108

Specifikus oldaldoboz tartó

BMW R1200GS (2013)

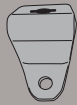

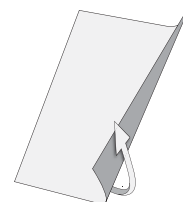
| N° | Megnevezés | Méret | Kód | Mennyiség | |
|----|------------------|----------------------|-----------|--------------|---|
| 1 | Oldaldoboz tartó | - | - | 2 (jobb,bal) |  |
| 2 | Hídelem | - | - | 1 |  |
| 3 | Rögzítőelem | Sp. 2,5mm | GL2350 | 2 (jobb,bal) |  |
| 4 | Rögzítőelem | Elülső (Sp. 4mm) | GL2367 | 2 (jobb,bal) |  |
| 5 | Rögzítőelem | Hátulsó (Sp. 4mm) | GL2366 | 2 (jobb,bal) |  |
| 6 | Rögzítőelem | Sp. 5mm | GL2365 | 2(jobb,bal) |  |
| 7 | Csavar | TBEI M8x35 | 835TBEI | 2 |  |
| 8 | Csavar | TBEI M8x50 | 850TBEI | 2 |  |
| 9 | Csavar | TECF M8x40 | 840TECF | 4 |  |
| 10 | Csavar | TBEIFN M6x16 | 616TBEIFN | 2 |  |
| 11 | Anyá | Karimás M6 | 6DADIAFLN | 2 |  |
| 12 | Alátét | Ø8 | 814RON | 4 |  |
| 13 | Alátét | Ø8x20 | 820RON | 4 |  |



PLR5108 – KLR5108

Specifikus oldaldoboz tartó

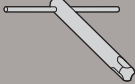
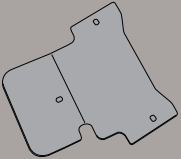
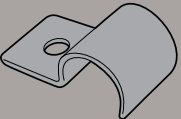
BMW R1200GS (2013)

| N° | Megnevezés | Méret | Kód | Mennyiség | |
|----|---------------------|-------------|----------|-----------|---|
| 14 | Eredeti alkatrészek | - | - | - | - |
| 15 | Speciális kulcs | - | - | 1 |  |
| 16 | Hővédő lemez | Sp. 2mm | GL2462 | 1 |  |
| 17 | Rögzítőelem | Sp. 1mm | GL2463 | 3 |  |
| 18 | Csavar | TBEIF M6x10 | 610TBEIF | 3 |  |
| 19 | Anya | | 6DADIAFL | |  |

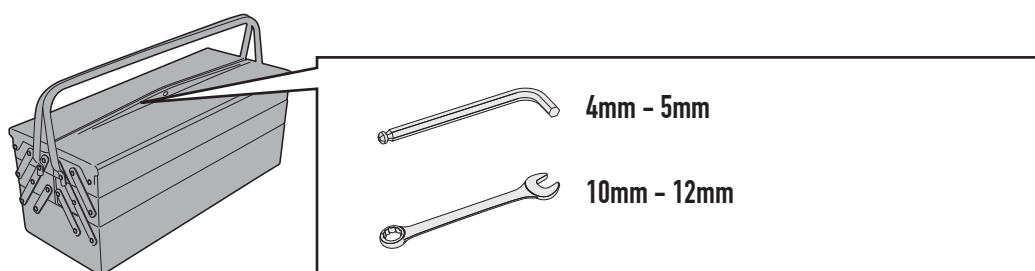
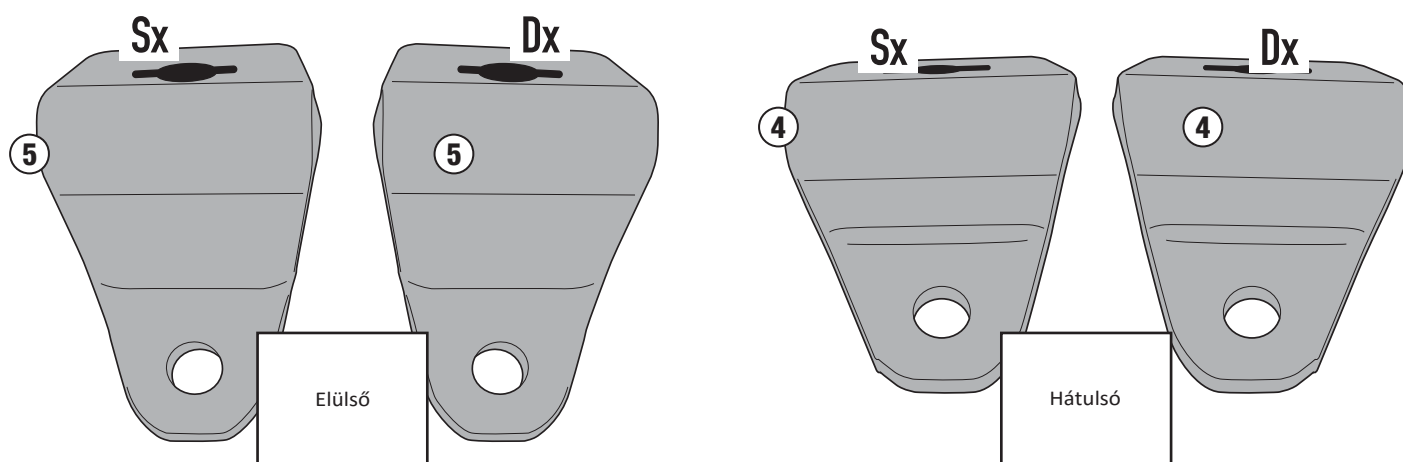

PLR5108 - KLR5108

Specifikus oldaldoboz tartó

BMW R1200GS (2013)

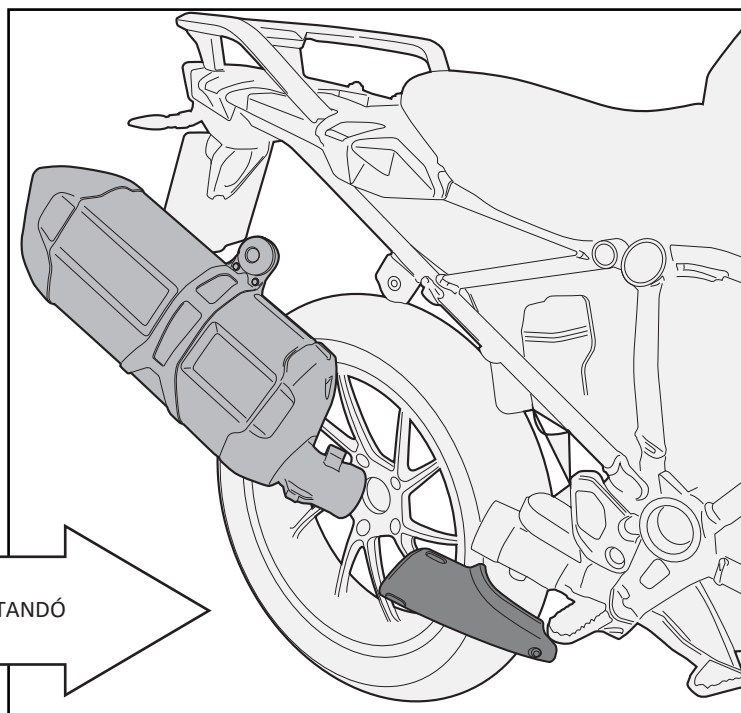
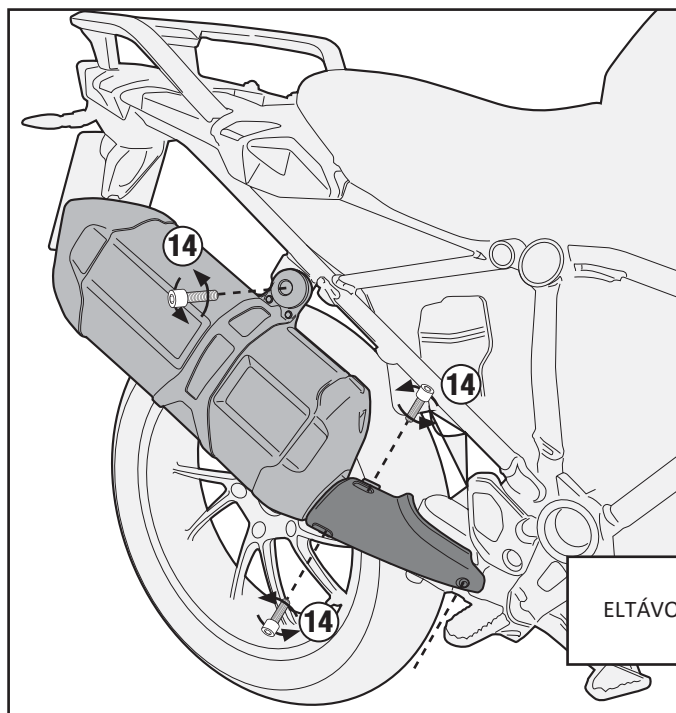
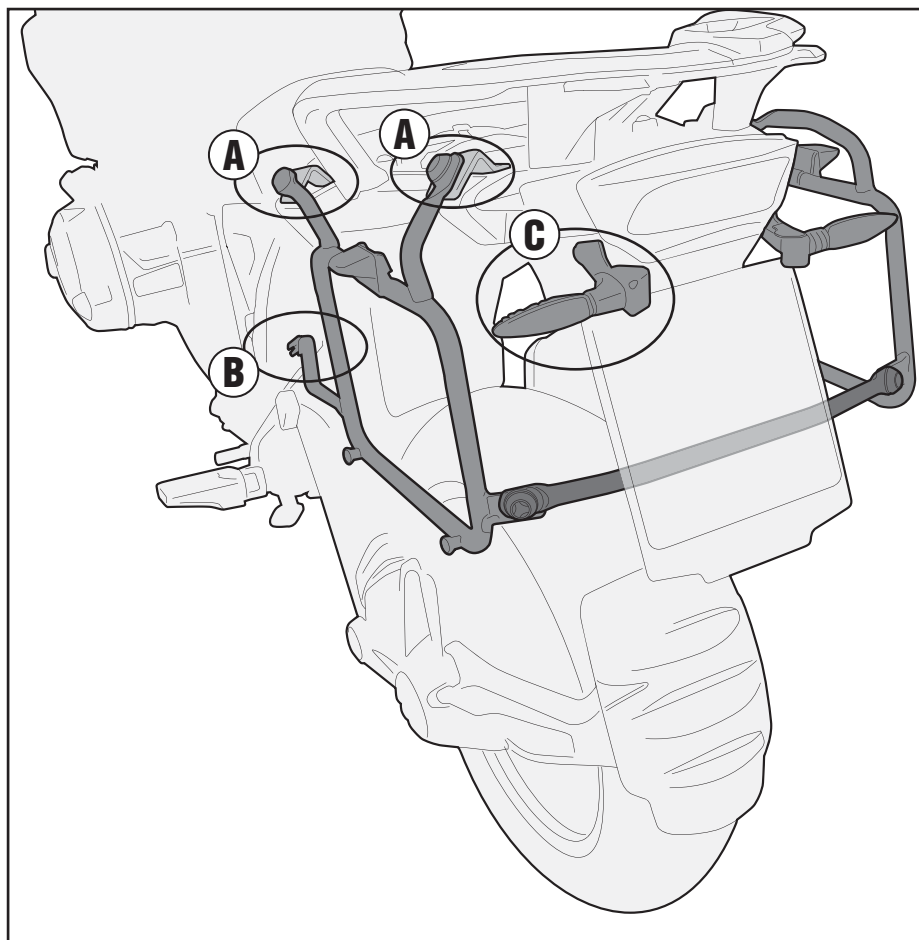

PLR5108 - KLR5108

Specifikus oldaldoboz tartó

BMW R1200GS (2013)

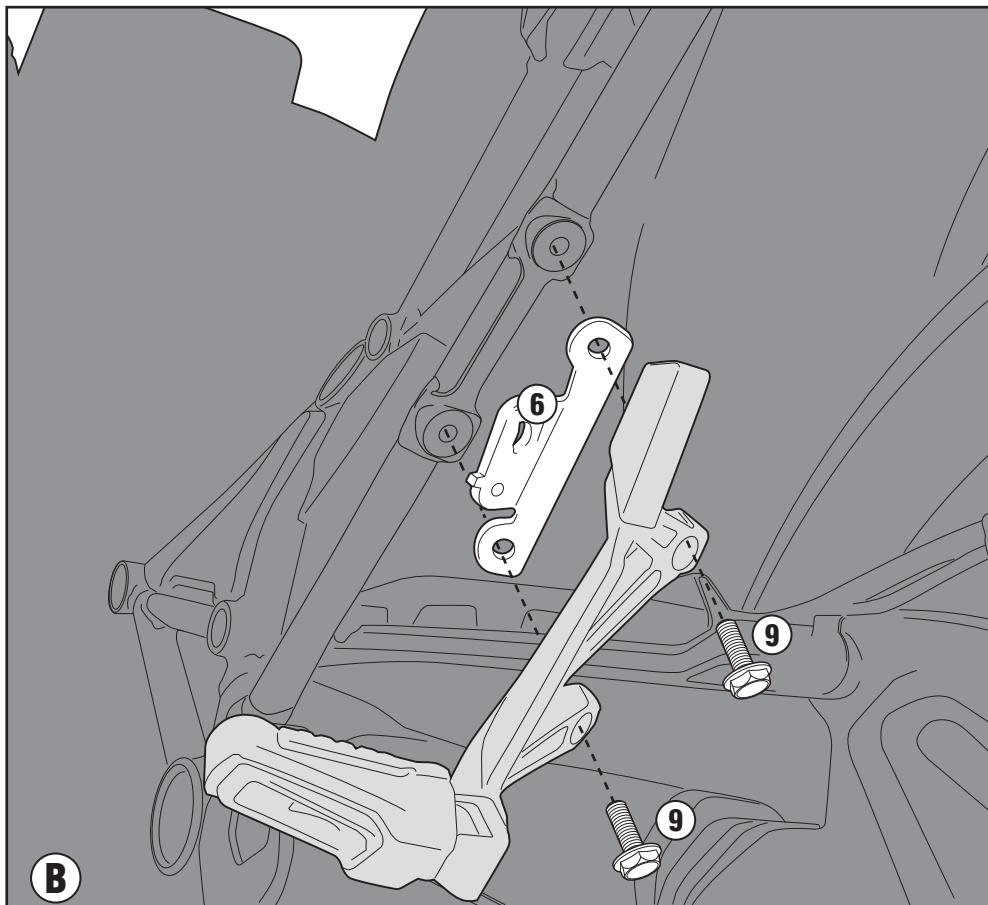
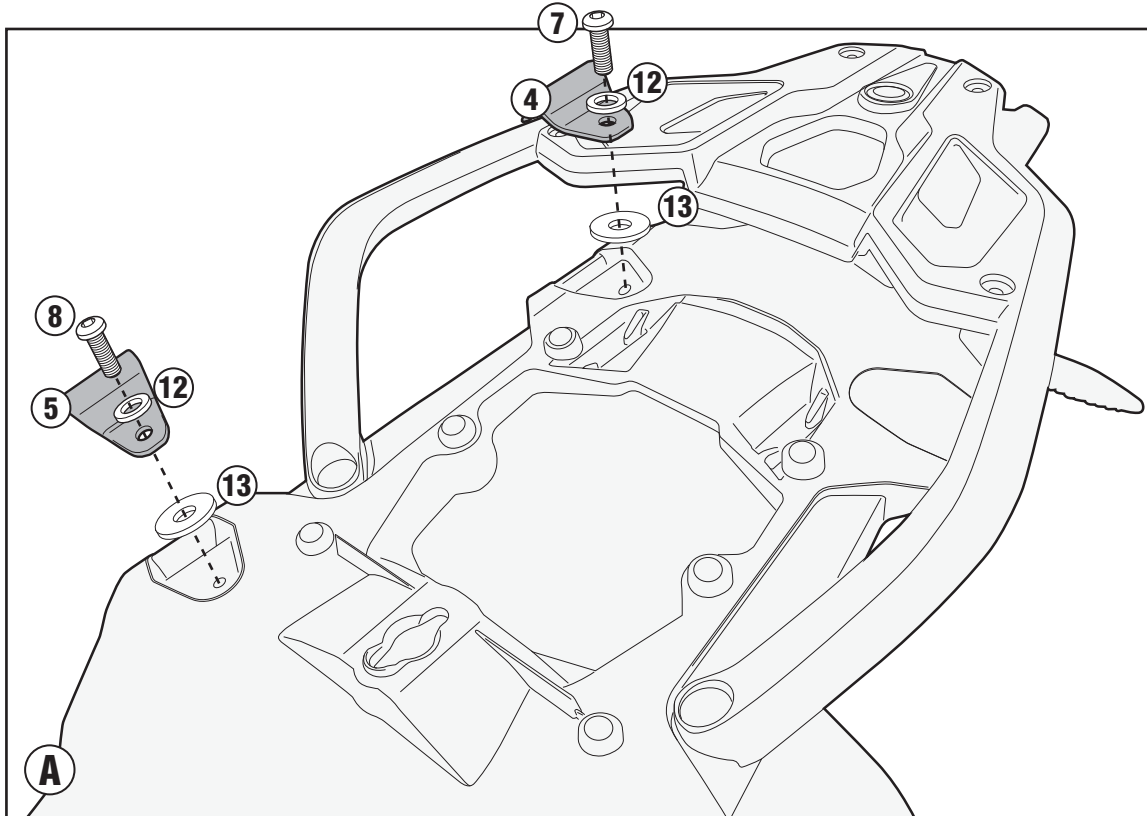

PLR5108 - KLR5108

Specifikus oldaldoboz tartó

BMW R1200GS (2013)

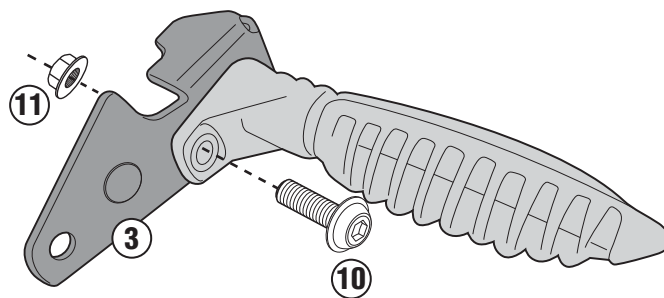
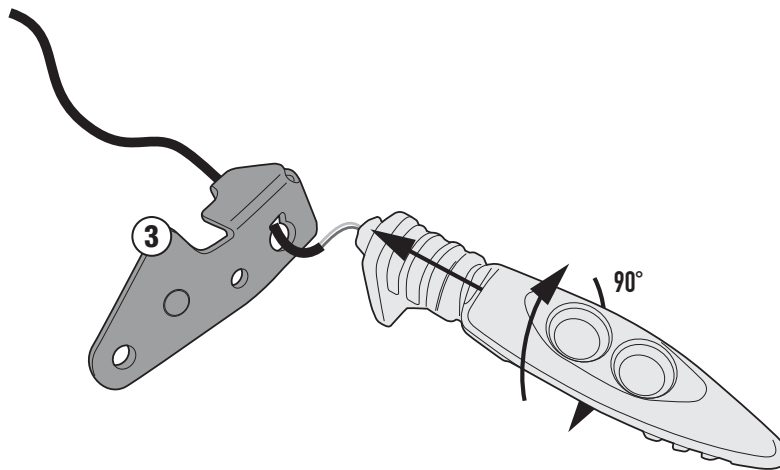
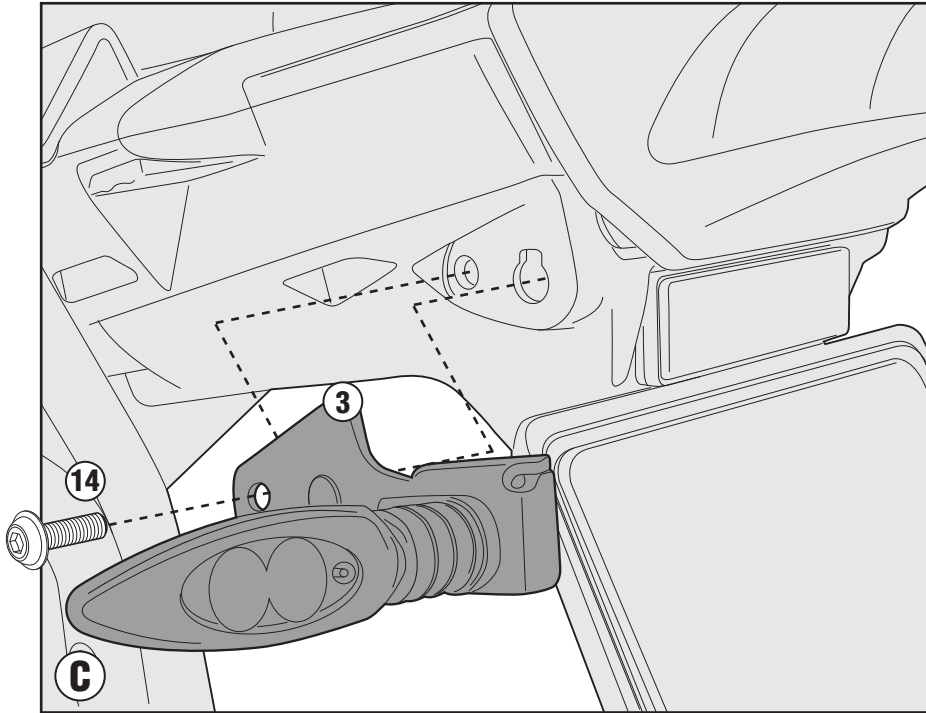

PLR5108 - KLR5108

Specifikus oldaldoboz tartó

BMW R1200GS (2013)

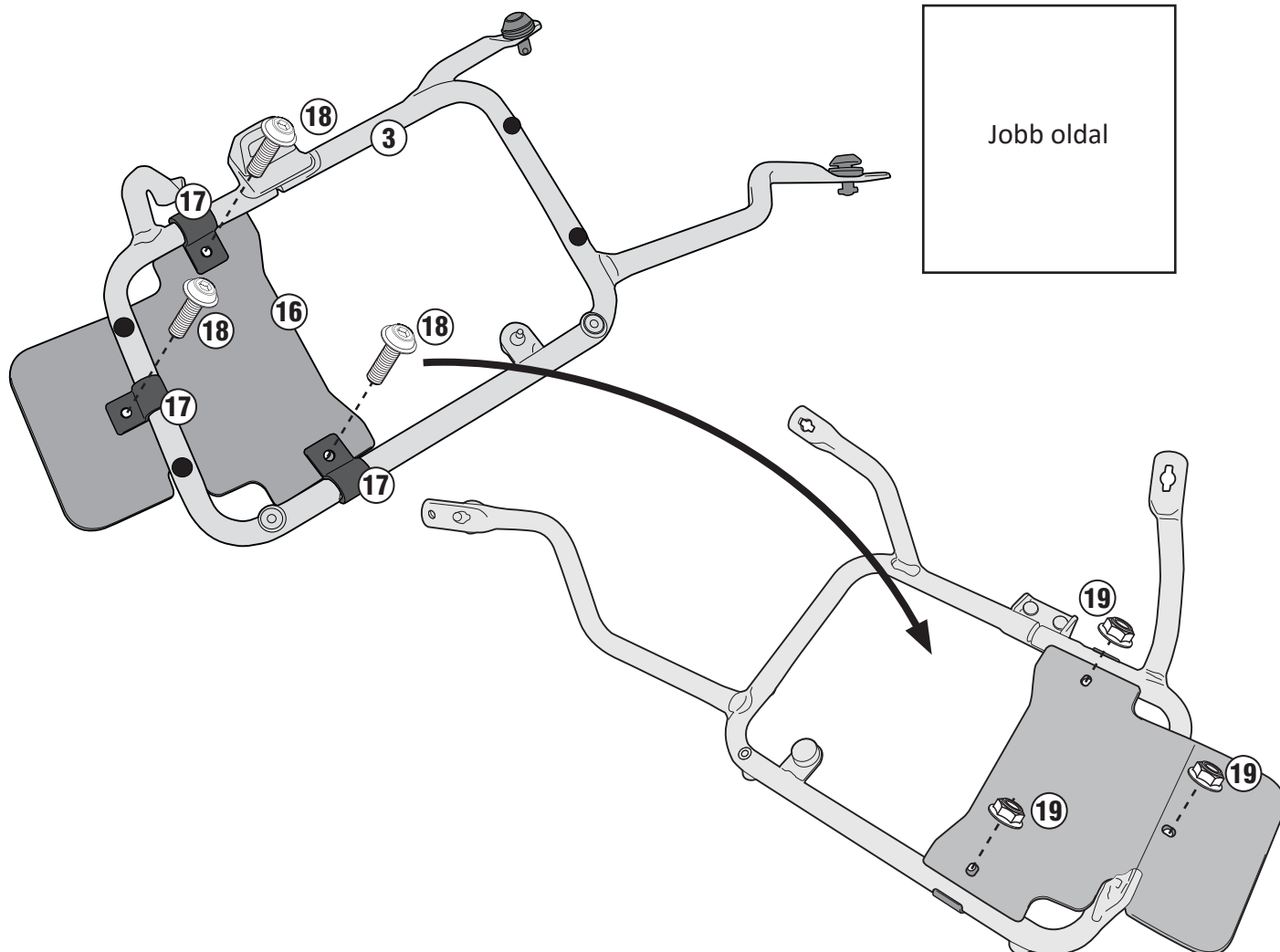
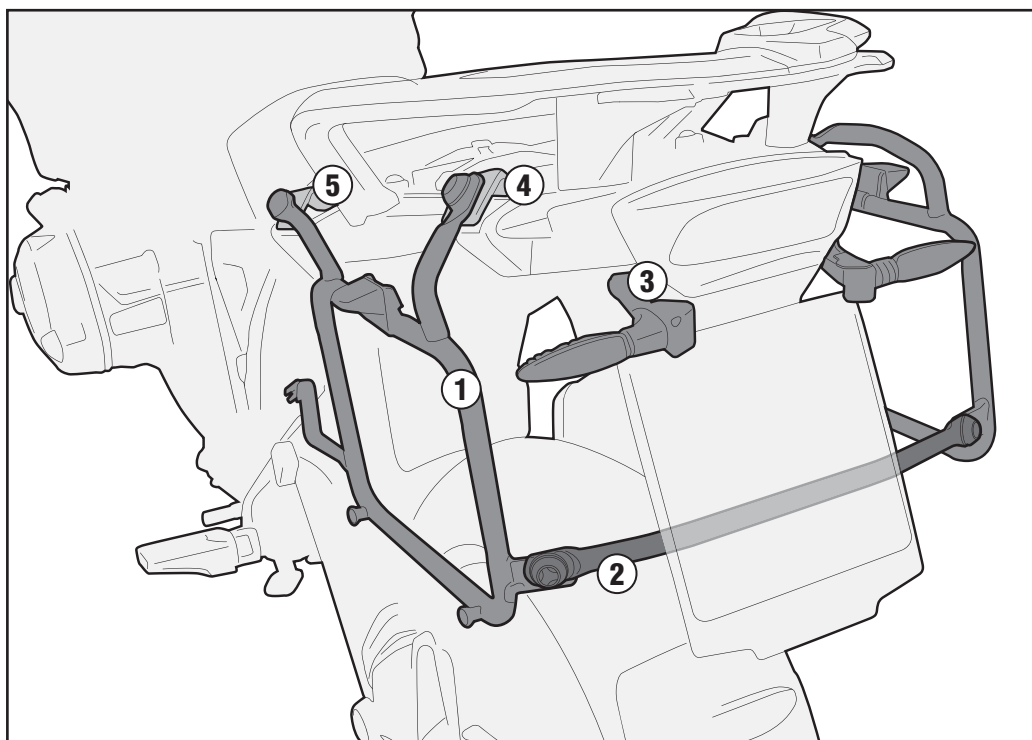

Jobb oldal

FELSZERELÉS/LESZERELÉS MONTÁZS PLR/PLXR

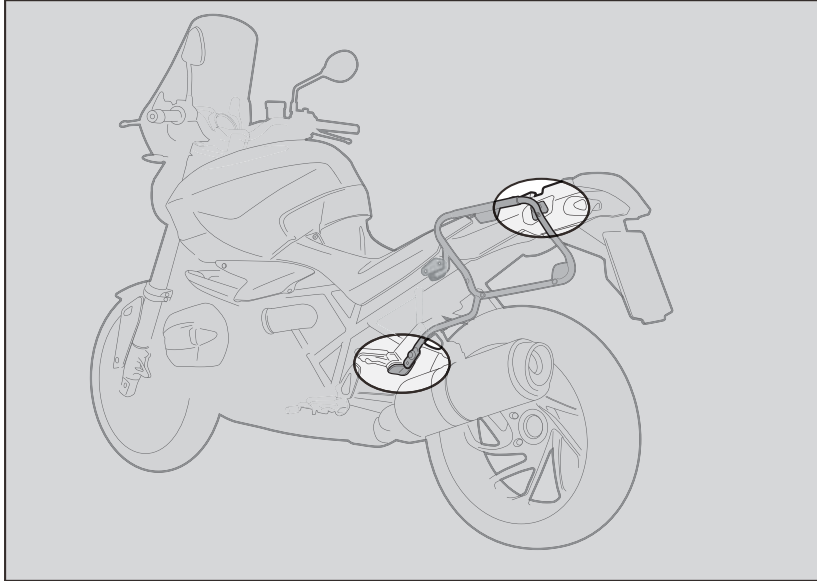

1. HELYEZZE A SPECIÁLIS KULCSOT A CSAVAR FEJÉBE
2. FORDÍTSA EL A KULCSOT ¼-EL AZ ÓRAMUTATÓ JÁRÁSÁNAK MEGFELELŐEN, AMÍGA FORGÁS MEGAKAD ÉS AZ OLDALTÁSKA TARTÓ ERŐSEN RÖGZÜL A FELSZERELÉSI PONTHOZ.
3. HA LE SZERETNÉ SZERELNI A KONZOLT, HAJTSA VÉGRE A MŰVELETET FORDÍTVA.

1. INSERT THE SPECIAL KEY INTO THE HEAD OF THE SCREW;
2. TURN THE KEY ¼ TURN CLOCKWISE UNTIL ROTATION STOPS AND THE SIDE CASE HOLDER IS FASTENED SECURELY TO THE FITMENT POINT;
3. IN ORDER TO DISASSEMBLE THE BRACKETRY PERFORM THE OPERATION IN REVERSE.

1. INSERER LA CLE SPECIALE DANS LA TÊTE DE LA VIS;
2. VISSER D'¼ DE TOUR DANS LE SENS HORAIRE JUSQU'AU BLOCAGE DE LA VIS POUR MONTER EN TOUTE SECURITE LE SUPPORT A SON POINT DE FIXATION;
3. POUR LE DEMONTAGE, PROCEDER EN SENSE INVERSE.

1. STECKEN SIE DAS WERKZEUG IN DEN KOPF DER SPEZIFISCHEN SCHRAUBE;
2. DREHEN SIE DIE SCHRAUBE ¼ UMDREHUNG IM UHRZEIGERSINN BIS SIE BEMERKEN, DASS DIE SCHRAUBE IM BEFESTIGUNGSPUNKT EINGEKLEMMT IST;
3. FÜR DIE DEMONTAGE FOLGEN SIE DEN HINWEISE UMGEKEHRT.

1. INSERTAR LA LLAVE ESPECIAL EN LA CABEZA DEL TORNILLO
2. DAR ¼ DE VUELTA EN EL SENTIDO HORARIO HASTA QUE LLEGUE AL TOPE Y SE VEA EL TORNILLO;
3. PARA DESMONTARLO PROCEDER EN LA DIRECCIÓN CONTRARIA;

FELSZERELÉS

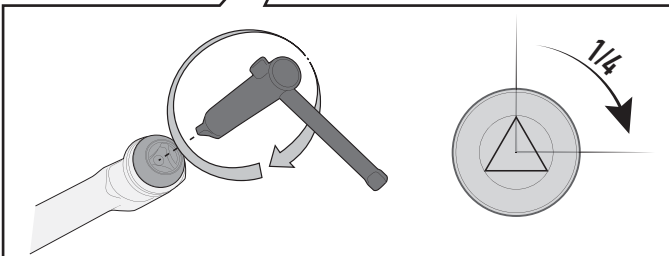
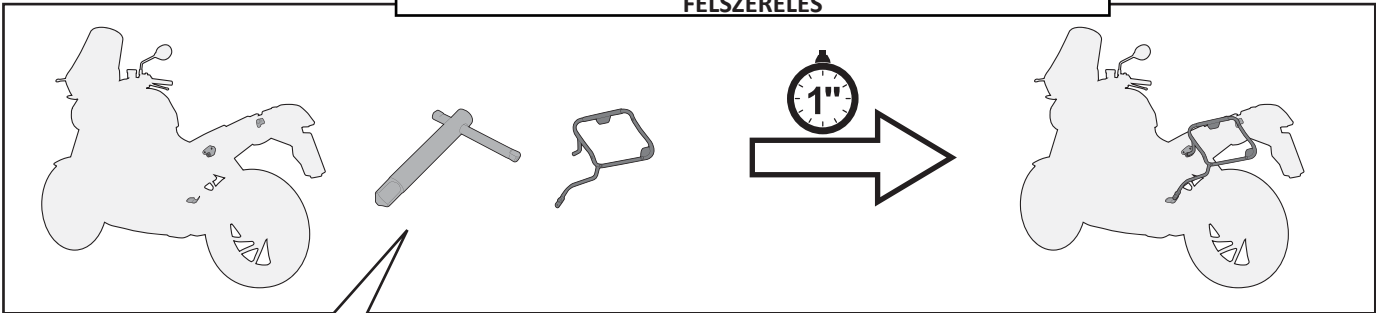

LESZERELÉS

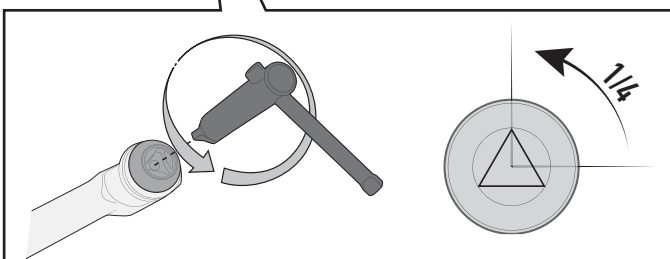
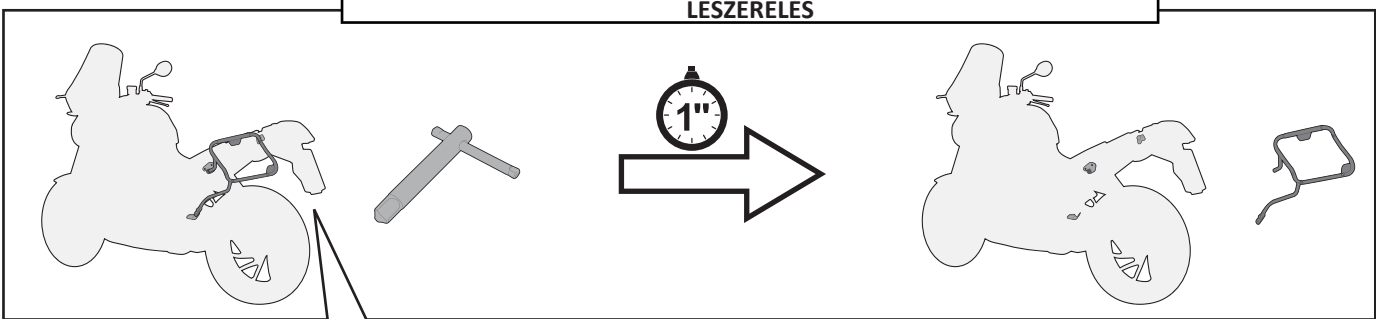

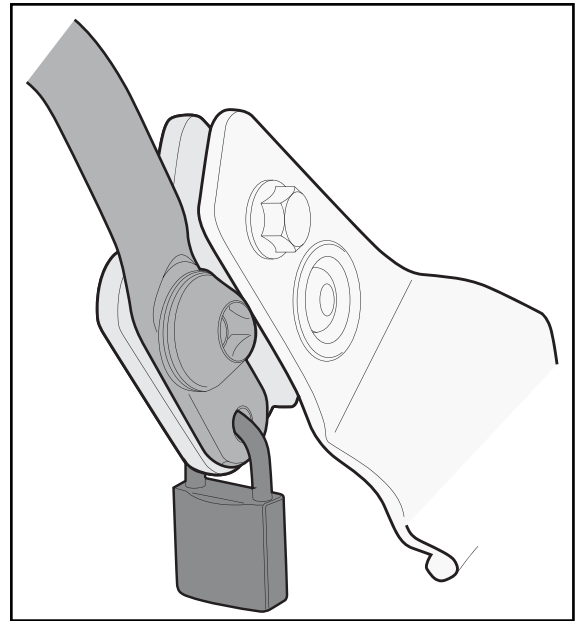
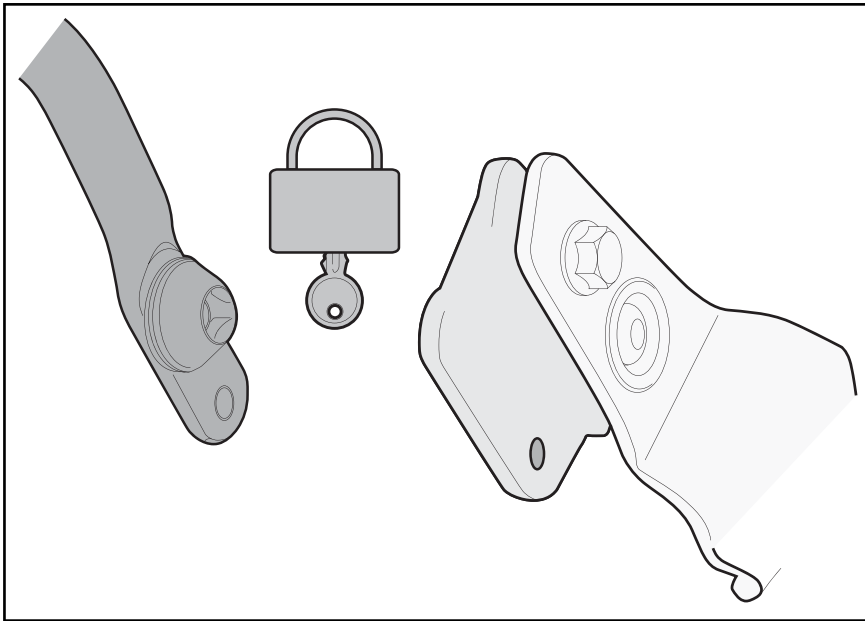
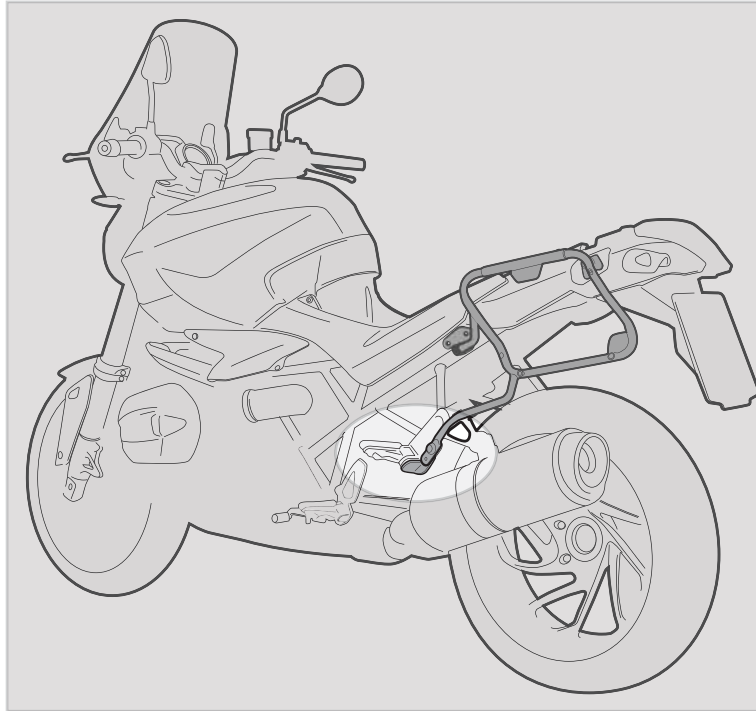

BIZTONSÁGI PONT

AZ ELHELYEZETT PONT SEGÍTSÉGÉVEL NAGYOBB BIZTONSÁGAL RÖGHZÍTHETŐ AZ OLDALDOBOZ TARTÓ KONZOL CSÖVE A MOTORHOZ (PÉLDÁUL EGY LAKATTAL, NINCS MELLÉKELVE).

SECURITY HOLE

HOLE PLACEMENT IN ORDER TO INCREASE SECURITY OF THE TUBULAR SIDE-CASE HOLDER TO THE MOTORCYCLE (WITH A LOCK, FOR EXAMPLE, NOT INCLUDED).

TROU DE SECURITE

TROU PREDISPOSE POUR ASSURER LE PORTE-VALISE LATERAL A LA MOTO (AVEC UN CADENAS PAR EXEMPLE, NON INCLUS).

SICHERHEITSLOCH

VORGESEHENES LOCH UM DEN SEITENKOFFER TRÄGER AN DEM FAHRZEUG ZU SICHERN (Z. B. MIT EINEM VORHÄNGESCHLOSS, NICHT ENTHALTEN);

ORIFICIO DE SEGURIDAD

ESTE ORIFICIO ESTA CREADO PARA ASEGURAR EL PORTAEQUIPAJES LATERAL A LA MOTO (POR EJEMPLO CON UN CANDADO, QUE NO ESTÁ INCLUIDO).